

11.A24.00..S099

SANIT ventilair active with threaded connections

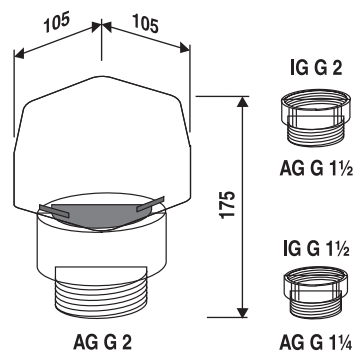

Item number

11.A24.00..S099

Product description

ventilair active with threaded connections

for accessible external areas for filtering gases arising in domestic sewage systems, toilet lifting systems, existing open vents, e.g. oil tanks, septic tanks, etc., with activated carbon filter monitored by TÜV Rheinland LGA Products GmbH, air flow volume at 250 PA = 3.33 l/s = 12 m³ h, frost resistant to -20degC in accordance with DIN EN 12380, UV light resistant plastic cover, with G2 male thread for use at pressures of up to 1 bar and two additional reducers with G1 1/2 and G1 1/4 male threads